

**HUMBOLDT COUNTY BUILDING DEPARTMENT  
MANUFACTURED HOUSE/MOBILE HOME RUNNERS & PERIMETER FOUNDATION**

These requirements apply to the construction of permanent foundations necessary to convert to real property. Humboldt County Ordinance 09-03-19 that any mobile home/manufactured home installed on runners or permanent foundations comply with the following requirements even if they are not converting to real property at the time of final inspection. All requirements for real property conversion shall be completed at the time of the final manufactured home inspection.

Note: Any home, which has existing runners below the exterior finished grade, shall not be approved for real property conversion unless an approved perimeter footing and stemwall is installed. This includes a house which is pit set & backfill has been installed against unapproved skirting walls.

**RUNNERS (Required to convert to real property)**

1. The beam footings must be at least 18" by 6" of continuous poured concrete running the length of the manufactured home, with two continuous ½" rebar in each runner. Marriage line footing shall be 20"x6" of continuous poured concrete running the length of the manufactured home, with two continuous #4 (½" rebar).
  - a. Provide a clearance of at least 3" around all rebar from forms and soils.
  - b. Rebar shall not be in contact with the ground.
  - c. Rebar shall not be pounded in the ground to support horizontal rebar.
  - d. Rebar shall be lapped a minimum of 20"
  - e. Runner shall be centered under the frame or exterior wall.
2. A minimum of 18" shall be required from the bottom of the chassis frame member to the top of the runner.
3. The foundation must support all load points recommended by the manufacturer of the home.
4. Perimeter blocking is required on every home. A footing 12" wide x 24" deep continuously poured the length of the home is required to support the perimeter blocking. (1) #4 rebar is required in the footing. Perimeter blocking shall be maintained at all times. If a perimeter foundation is installed runners will be required based on the requirement for real property conversion and the Nevada Division of Manufactured Housing Guidelines
5. Supporting piers shall be installed per Humboldt County Set-Up Manual. Supporting metal piers shall be placed directly on the runner. If using concrete blocks a minimum ½" pressure treated wood or plywood of a size equal to the block shall be placed between the concrete blocks and the runner.
6. Blocking:  
Main Blocking – Located within 12" of each end and 6' o.c.  
Marriage Line Blocking – Spacing 8' o.c.  
Perimeter Blocking – 6" or less from each corner and 8' o.c.
7. Tiedowns shall be installed in the footing per the tiedown manufacturer's instructions. Spacing on the tiedowns shall be 11' o.c. on the outside footings and (1) at each end of the interior footings or installed other approved tiedown system for foundation. The first and last tie down shall be placed within 2' of the end of the footing, Tiedowns shall be installed at the time of the runner inspection. Provide a hole under the tiedowns for a minimum 3" concrete under tiedown.  
Longitudinal tiedowns shall be installed to the devices manufacturer's instructions. If the number of devices to be used is not mentioned or is unclear, an minimum of one device for each direction (one in each corner) per chassis main beam must be used (8 total).  
Strapping must comply with Humboldt County Set-Up Manual. Other systems shall be approved by the Nevada State Manufactured Housing Division.
8. The axles and the tongues are required to be removed. They shall not be stored under the manufactured/mobile home.
9. Existing runners installed previously to November 1, 2006 shall comply with this handout except longitudinal tiedowns will not be required. If tiedowns required on existing complaint runners typical tiedown heads with strapping shall be installed by approved bolting to concrete.

**Perimeter Foundation (Footing & Stemwall) (Not required for real property conversion)**

10. Footings and foundations shall extend below the frost line and be continuous. IRC Section R403.1.1.1 & 403.1.2)
11. Footings shall be a minimum of 6"x12". Stemwall shall be a minimum of 6"x28".
12. (2) ½" diameter bars (#4) rebar continuous in the footing with a minimum of 3" clearance from bottom of footing. No rebar shall come in contact with the earth. (IRC Section R319.1(5) & R401.1.6). Rebar shall be located in the stemwall footing and runner where frame support is required.
13. A 28" minimum stemwall is required. This is measured from the top of the stemwall to the top of the footing. (Max. 48" stemwall height)
14. Masonry walls shall be solidly grouted.
15. Vertical rebar  
½" diameter (#4) rebar 32" o.c. The vertical rebar shall extend 3" clear of bottom of footing have a standard hook & extend a min. of 14" into the stemwall(IRC Section R403.1.3). Vertical rebar shall be tied to horizontal rebar in footings per IRC Section R404.1.4(6). Rebar shall not be bent with heat. When lapping rebar the rebar shall be lapped a minimum of 20" for ½" rebar (#4)
16. One ½" (#4) rebar shall be provided at the top of the stemwall located directly below vents. (IRC Section 403.1.3.1)
17. Plates, sill or sleepers shall be a min. 2"x4" or 2"x6" pressure treated. (IRC R318 & R319.1)
18. Foundation plates or sills shall be bolted to the foundation or foundation wall not less than ½" bolts, embedded at least 7" into concrete & spaced not more than 6' o.c. There shall be a minimum of two bolts per piece with one bolt located not more than 12" of each end of each piece. Place washers a min. of ¼"x3"x3" thick shall be used on each bolt. A properly sized nut shall be tightened on each bolt to the plate. (IRC Sections 403.1.6 & R602.11.1). ***Anchor bolts can be countersunk in the sill plate for manufactured homes only. If the anchor bolts are countersunk a min. 2"x6" pressure treated sill plate or (1) pressure treated 2"x4" & (1) 2"x4" doug fir is required.***  
Alternative mudsill anchors can be used in place of anchor bolts. Anchors such as Simpson MASB or equivalent. Proper anchor shall be used for the size of mudsill. The anchor must be installed to the manufacturer's instructions such as spacing, embedment and attachment to sill plate.
19. Trenches under footings shall be kept to a minimum to provide adequate support of the footings.

**Crawl Space Access & Ventilation (Runners & Perimeter Foundation)**

20. All wood and similar material used in the blocking and the perimeter enclosure must be pressure treated. Backfill against skirting shall not be permitted. See Humboldt County Set-Up Manual for skirting requirements.
21. The crawl space between the bottom floor structure of the manufactured home and the footing pad must be at least 28" in height. A minimum of 18" shall be required from the bottom of the chassis frame member to the top of the runner. Access to the crawl space must be by an opening which is 23"x24" or larger. The access well shall be 24"x36". The opening shall have a cover provided and should be closed when not in use. Pipes and piers must not interfere with access to or within the space below the floor. A minimum of 30" clear space shall be provided directly in front of each access panel or door outside the perimeter of the home.
22. Underfloor areas shall be ventilated by openings of 1 s.f./150 s.f. of floor area. One opening shall be within 3" of each corner. Close with ¼" mesh. (IRC Section R408.2) Vents shall not be closable. Minimum of 8 vents is required.
23. Vapor retarder shall be provided on the ground within the enclosed crawl space. The vapor retarder shall be a black 6 mil thick continuous membrane placed over runners & under jacks.. Seams shall be overlapped 8". A barrier shall not be installed in an open deck area.
24. Open porches or decks must be separated from the crawl space with a footing & wall barrier a minimum of 12" in height. Footing and barrier wall shall be concrete with a 6" min. width.

**Additional Requirements**

25. Finished grade of 5" horizontally away from home foundations or skirting shall be provided. Uncovered slabs, patios, or walks shall slope away from home and structures in order to drain water away from home and structures.
26. Provide stairs and landings at all door openings. Stairs, landings, handrails and guardrails shall comply with all code requirements. Further details of above can be requested from the Building Department.
27. Utilities:
  - a. The water line shall transition from PVC to an approved pipe (CPVC, PEX or copper) outside of the foundation or skirting of the manufactured home. A water shut-off valve shall be provided to frost line at the exterior of the house at the pipe transition point.
  - b. MH service equipment shall be located within site and not more than 30' from the exterior wall of the manufactured home. This means if the service is located more than 30' away from the manufactured home a disconnect will be required within 30' of the manufactured home.

Note: Inspections shall be requested before concrete is poured.

**MANUFACTURED HOME RUNNER**

1. Footing must be a minimum of 18" wide by 6" deep of continuous poured concrete runner the length of the manufactured home, with two continuous 1/2" rebar (#3). Marriage line shall be 20" wide by 6" deep continuously poured concrete with two continuous 1/2" (#4) rebar. Maintain a minimum of 2" clearance around rebar. Rebar shall not be contact with the ground. Rebar shall not be pounded in ground to support horizontal rebar.
2. Tie downs shall be spaced on outside of runners beginning no more than 2' from each end and no more than 11' o.c. & on each end of interior runners or other approved system. Concrete tie down anchors shall be placed per drawing. Provide a hole under tie down anchor so the anchor is fully embedded and provided with a minimum of 3" of concrete under anchor.
3. Runners shall be installed with 12" wide x 24" deep continuously poured footing the length of the home to support the perimeter blocking. If future stemwall to be installed all four sides of home require a continuous footing to frost line.

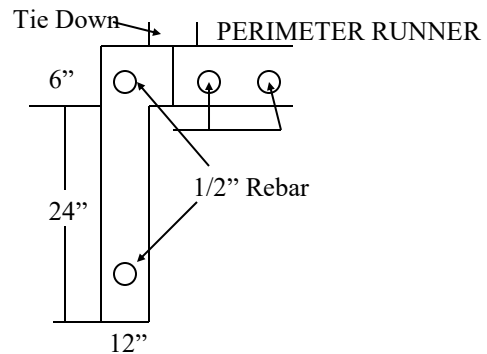
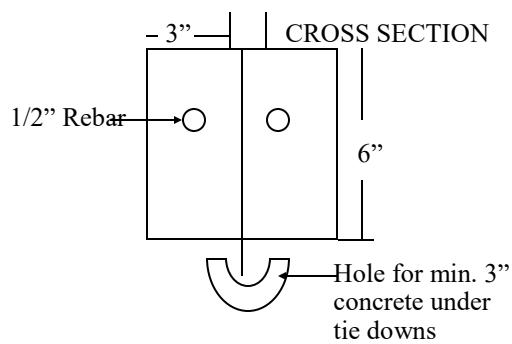
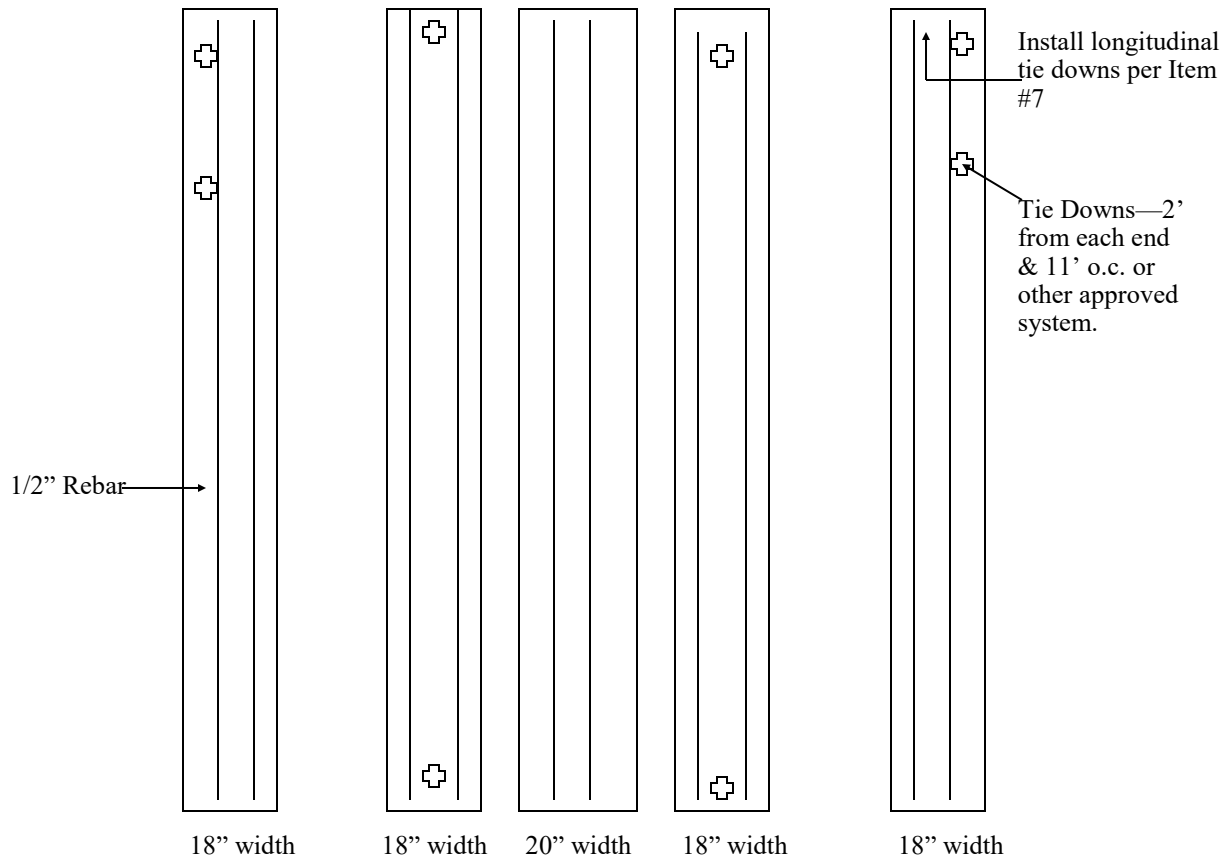

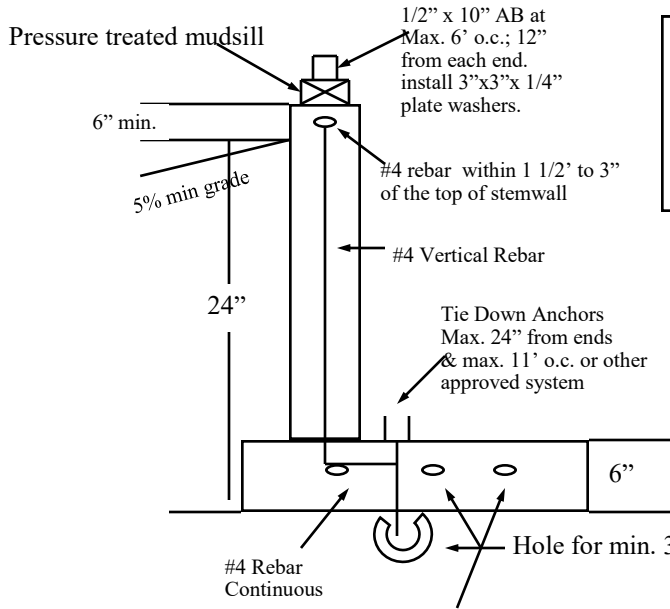

Alternative mudsill anchors can be used in place of AB. Anchors such as Simpson MASB or equivalent. Proper anchor shall be used for size of mudsill (2x4 or 2x6). The anchor must be installed to the manufacturer's instructions such as spacing, embedment and attachment to sill plate.

All stemwall height—  
6" x 28" min.  
6" x 48" max.

Longitudinal tie downs required per Page 7

Poured Concrete Perimeter Foundation

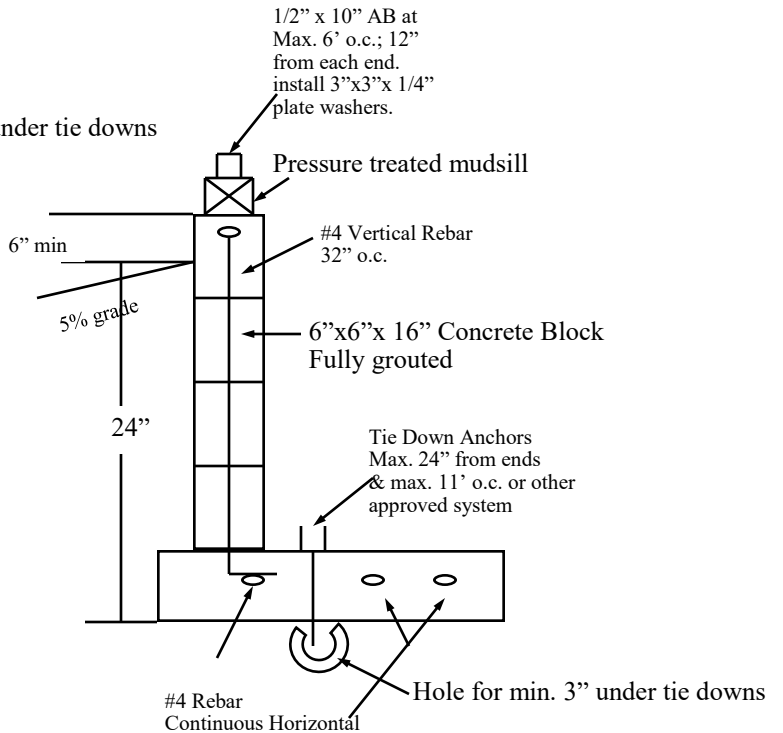

Concrete Block Perimeter Foundation

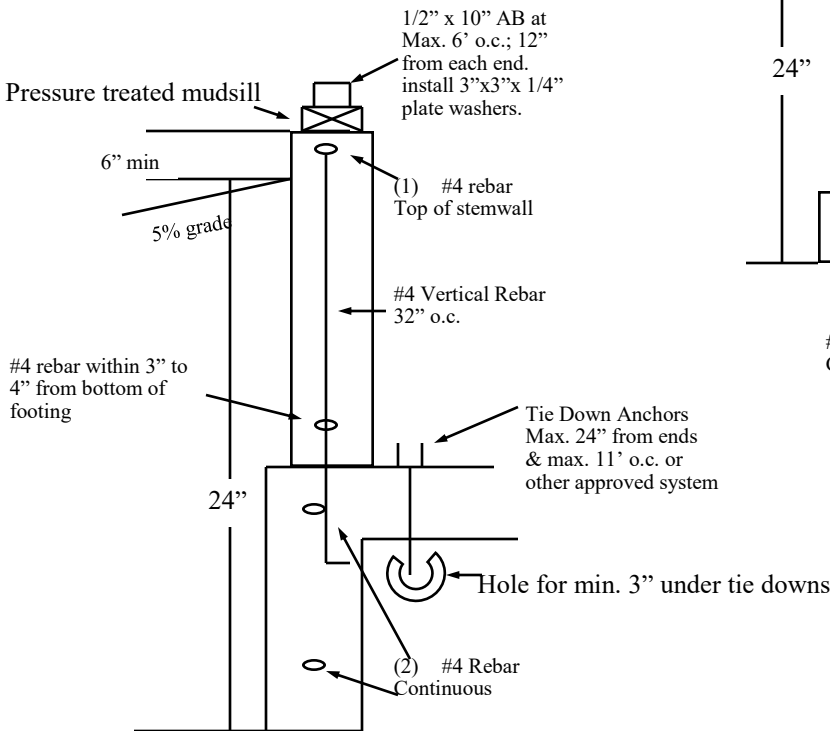

18" shall be provided from the top of the runner to the bottom of the frame member.

MANUFACTURED HOME PERIMETER FOUNDATION DETAILS

SEE WRITTEN SPECIFICATIONS FOR DETAILS

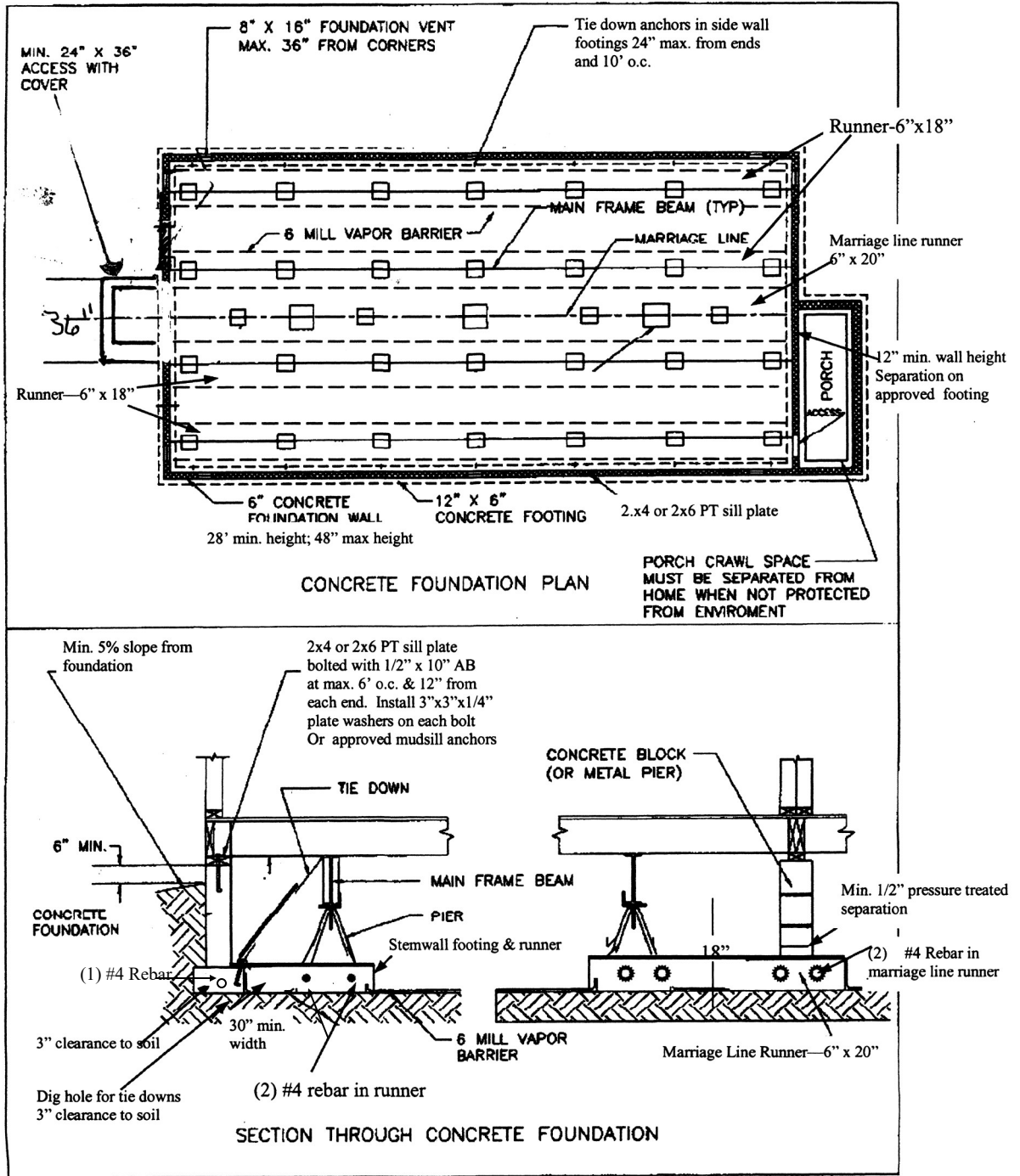

SEE WRITTEN SPECIFICATIONS FOR DETAILS