

HUMBOLDT COUNTY BUILDING DEPARTMENT
CITY OF WINNEMUCCA
ACCESSIBLE PARKING SPACE

Referenced Code: ICC/ANSI A117.1-2017 & 2018 International Building Code

Parking Spaces (Section 502)

Vehicle Space Size: Car parking spaces shall be 96" minimum in width. Van parking spaces shall be 132" minimum in width.

Exception: Van parking spaces shall be permitted to be 96" minimum in width where the adjacent access aisle is 96" minimum in width.

Vehicle Space Marking: Car and van parking spaces shall be marked to define the width. Where parking spaces are marked with lines, the width measurements of parking spaces and adjacent access aisles shall be made from the centerline of the markings.

Access Aisle: Car and van parking spaces shall have an adjacent access aisle.

Location: Access aisles shall adjoin an accessible route. Two parking spaces shall be permitted to share a common access aisle. Access aisles shall not overlap the vehicular way. Parking spaces shall be permitted to have access aisles placed on either side of the car or van parking space. Van parking spaces that are angled shall have access aisles located on the passenger side of the parking space. (502.4.1)

Width: Access aisles serving car and van parking spaces shall be 60" minimum in width. (502.4.2)

Length: Access aisles shall extend the full length of the parking spaces they serve. (502.4.3)

Marking: Access aisles shall be marked so as to discourage parking in them. Where access aisles are marked with lines, the width measurements of access aisles and adjacent parking spaces shall be made from the centerline of the markings. (502.4.4)

Floor Surface: Parking spaces and access aisles shall be stable, firm, and slip resistant (302.1) and have surface slopes not steeper than 1:48. Access aisles shall be at the same level as the parking spaces they serve. (502.5)

Vertical Clearance: A vertical clearance of 98" minimum shall be provided at the following locations: (502.6)

1. Parking spaces for vans
2. The access aisles serving parking spaces for vans
3. The vehicular routes serving parking spaces for vans.

Identification: Where accessible parking spaces are required to be identified by signs, the signs shall include the International Symbol of Accessibility complying with Section 703.6.3.1. Signs identifying van parking spaces shall contain the designation "van accessible". Such signs shall be 60" minimum above the floor of the parking space, measured to the bottom of the sign. (502.7)

Relationship to Accessible Routes: Parking spaces and access aisles shall be designed so that cars and vans, when parked, cannot obstruct the required clear width of adjacent accessible routes. (502.8)

Parallel Parking Spaces: On-street parallel parking spaces shall comply with Section 502.9.1. Where the width of the adjacent sidewalk or available right-of-way exceeds 14 feet, an access aisle 60 inches wide minimum shall be provided at street level the full length of the parking space and shall connect to a pedestrian access route. The access aisle shall comply with Section 502.4 and shall not encroach on vehicular travel lanes (502.9.1).

Alterations. In alterations where the street or sidewalk adjacent to the parking space is not altered, an access aisle shall not be required provided the parking spaces are located at the end of the block face (502.9.1.1).

Narrow sidewalk. An access aisle is not required where the width of the adjacent sidewalk or the available right-of-way is less than or equal to 14 feet. Where an access aisle is not provided, the parking spaces shall be located at the end of the block face.

Perpendicular or Angled Parking Spaces: Where perpendicular or angled parking is provided, an access aisle 96 inches wide minimum shall be provided at street level the full length of the parking space and shall connect to a pedestrian access route. The access aisle shall comply with Section 502.4 and shall be marked so as to discourage parking in the access aisle. Two parking spaces are permitted to share a common access aisle (502.9.2)

Passenger Loading Zones (Section 503)

Vehicle Pull-Up Space Size: Passenger loading zones shall provide a vehicular pull-up space 96" minimum in width and 20' minimum in length. (503.2)

Access Aisle: Passenger loading zones shall have an adjacent access aisle.

Location: Access aisles shall adjoin an accessible route. Access aisles shall not overlap the vehicular way. (503.3.1)

Width:

New buildings and facilities: In new buildings and facilities, aisles serving vehicle pull-up spaces shall be 67 inches in width. (503.2.1)

Existing buildings and facilities: In existing buildings and facilities, aisles serving vehicle pull-up spaces shall be 60 inches minimum in width. (503.3.2.2)

Length: Access aisles shall extend the full length of the vehicle pull-up space they serve. (503.3.3)

Marking: Access aisles shall be marked so as to discourage parking in them. (503.3.4)

Floor Surfaces: Vehicle pull-up spaces and access aisles serving them shall be stable, firm, and slip resistant (302.1) and shall have slopes not steeper than 1:48. Access aisles shall be at the same level as the vehicle pull-up they serve. (503.4)

Vertical Clearance: A vertical clearance of 114" minimum shall be provided at the following locations: (503.5)

1. Vehicle pull-up spaces
2. The access aisles serving vehicle pull-up spaces
3. A vehicular route from an entrance to the passenger loading zone
4. A vehicular route from the passenger loading zone to a vehicular exit serving vehicle pull-up spaces.

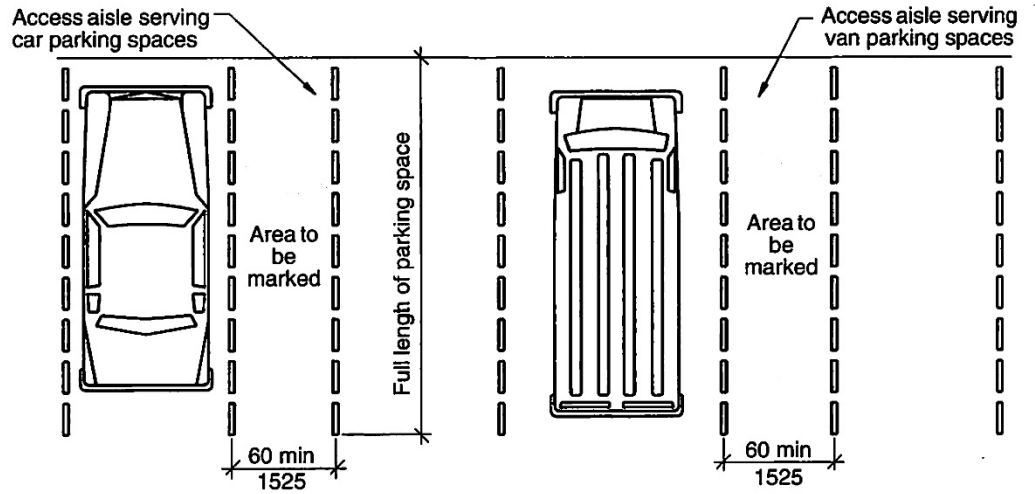

PARKING SPACE ACCESS AISLE

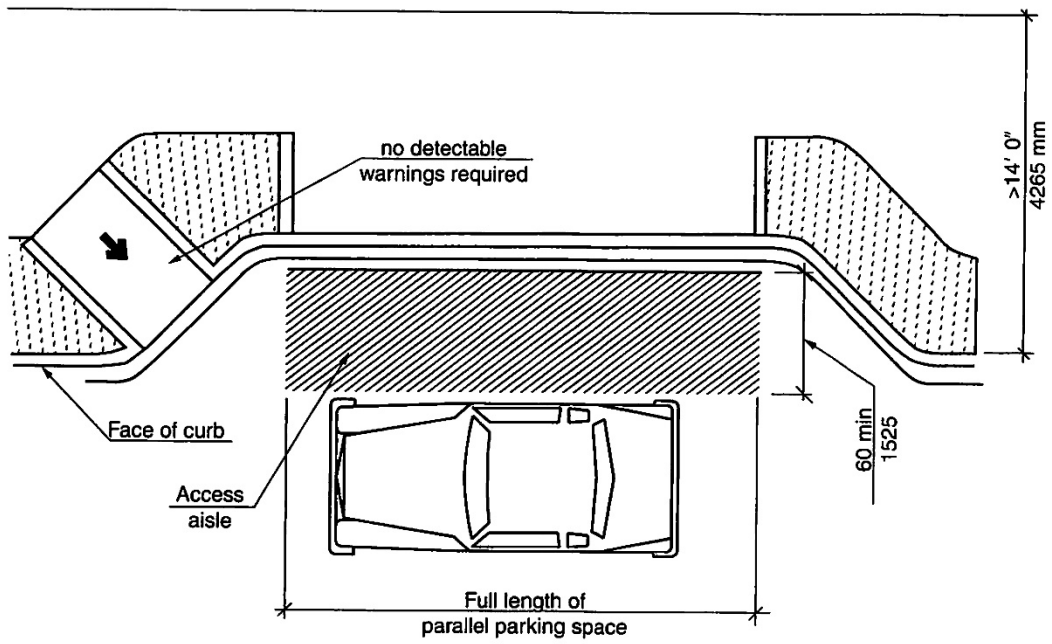

WIDE SIDEWALKS

GENERAL SITE AND BUILDING ELEMENTS

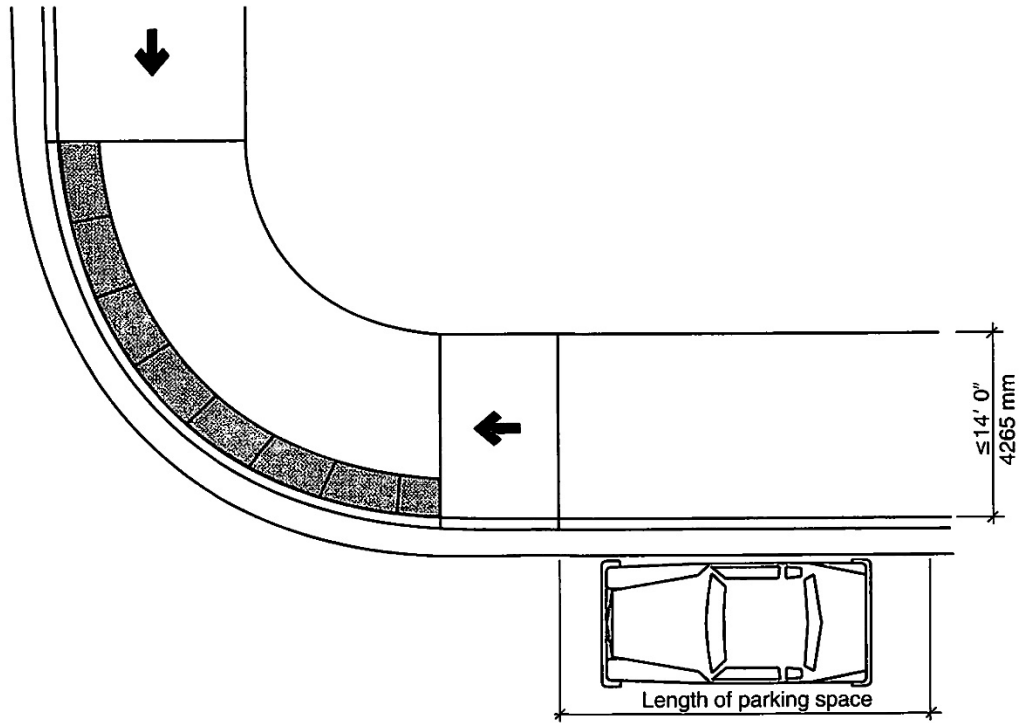

NARROW SIDEWALKS

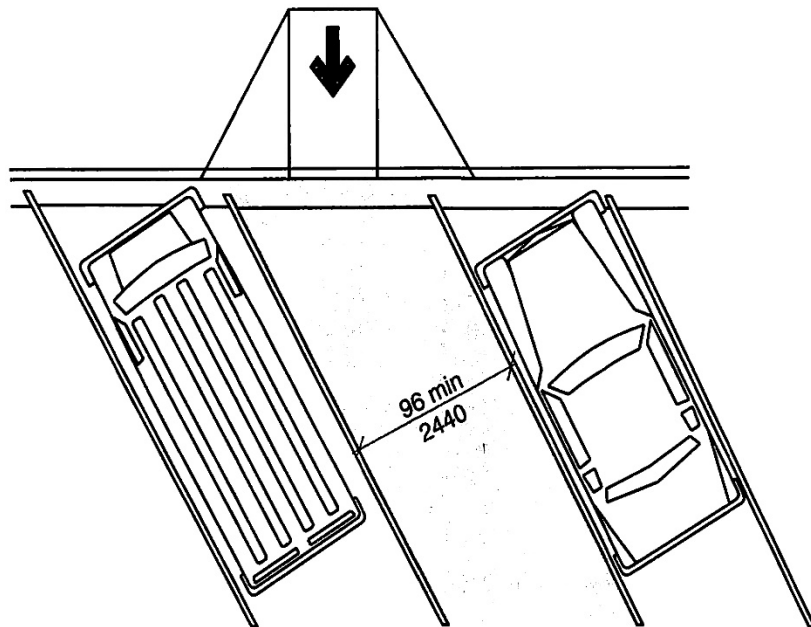

PERPENDICULAR OR ANGLED PARKING SPACE

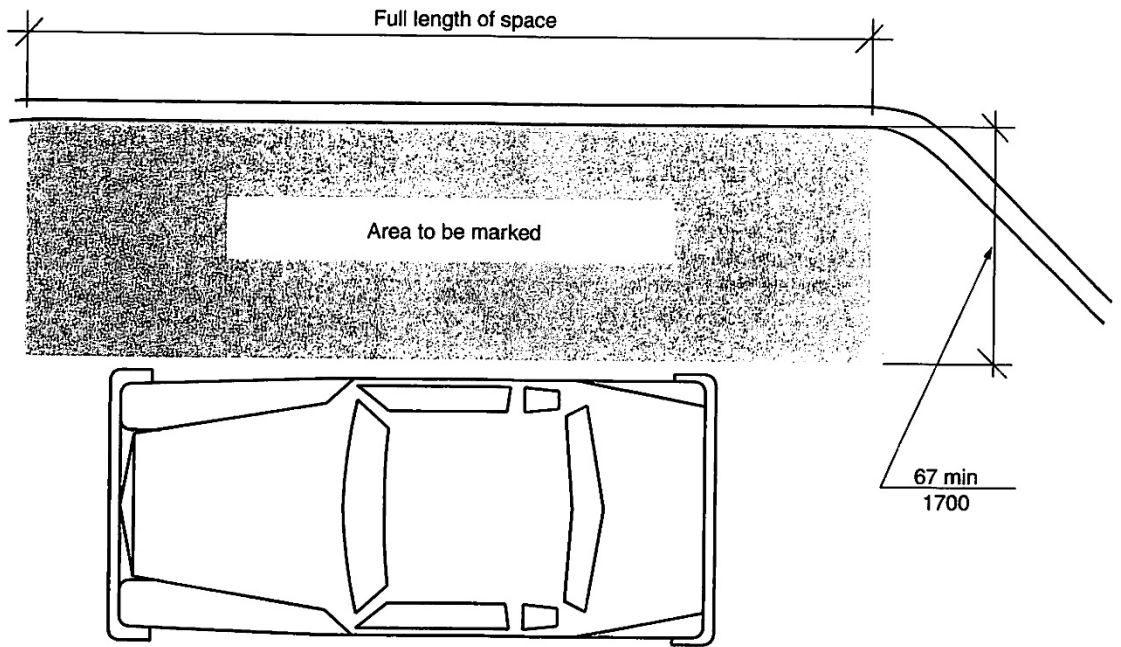

PASSENGER LOADING ZONE ACCESS AISLE - NEW BUILDINGS

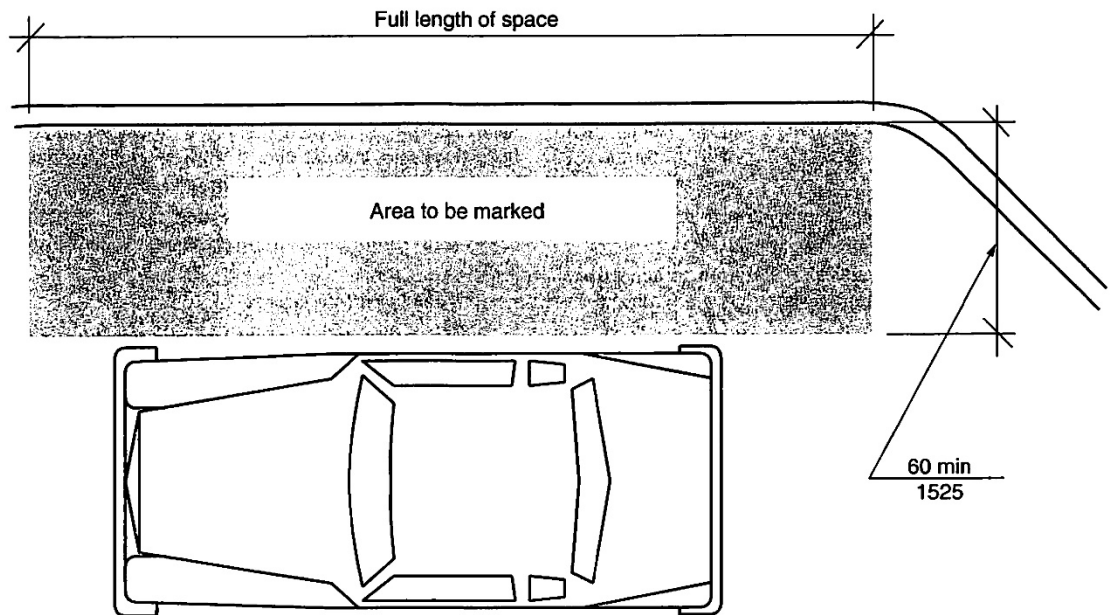

PASSENGER LOADING ZONE ACCESS AISLE - EXISTING BUILDINGS

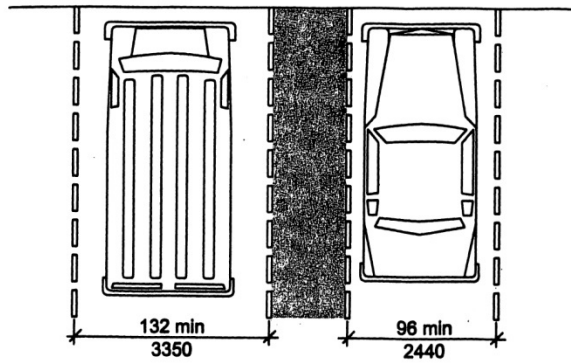

**FIG. 502.2
VEHICLE PARKING SPACE SIZE**

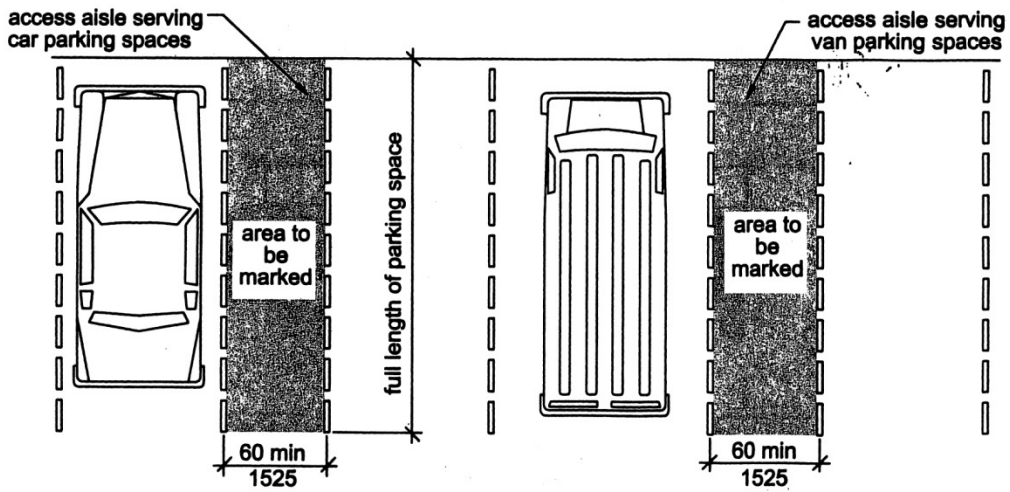

**FIG. 502.4
PARKING SPACE ACCESS AISLE**

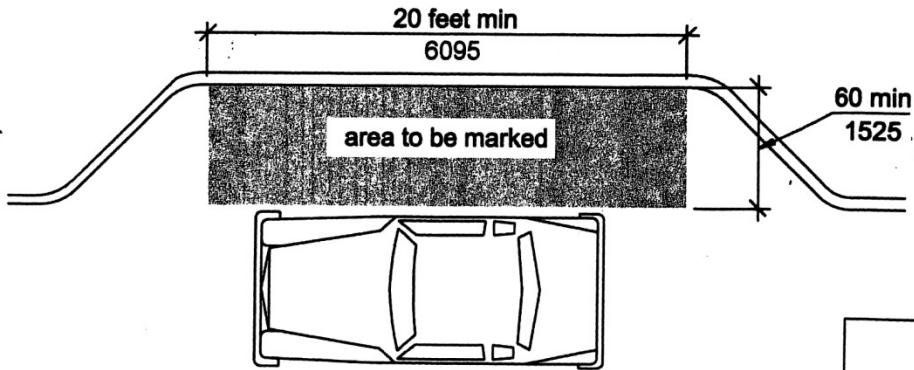

**FIG. 503.3
PASSENGER LOADING ZONE ACCESS AISLE**



**FIG. 703.6.3.1
INTERNATIONAL SYMBOL OF ACCESSIBILITY**